

# QSFP-40G-ER4

## Optical SFP Module

40Gbps QSFP+ ER4 Transceiver, SM, 40KM



### Features

- High Channel Capacity: 40 Gbps per module
- Transmission data rate up to 11.2Gbps per channel
- Duplex LC receptacle
- 4 parallel lanes design
- Maximum link length of 40km
- Hot Pluggable QSFP+ form factor
- Real Time Digital Diagnostic Monitoring
- Maximum power consumption 3.5W
- Single +3.3V power supply
- Compatible with RoHS
- Commercial operating case temperature: 0 to +70° C

### Application

- 40GBASE-ER4 40G Ethernet links
- Infiniband QDR, DDR and SDR
- Datacenter and Enterprise networking

## Standard

- Compliant with IEEE 802.3ba
- Compliant with QSFP+ MSA
- Compliant with SFF-8436

## Absolute Maximum Ratings

Parameter	Symbol	Min	Max	Unit
Supply Voltage	Vcc	0	3.6	V
Storage Temperature	Ts	-40	+85	°C
Operating Humidity	-	5	95	%

## Recommended Operating Conditions

Parameter	Symbol	Min	Typical	Max	Unit
Operating Case Temperature (Commercial)	Tc	0		+70	°C
Power Supply Voltage	Vcc	3.13	3.3	3.47	V
Power Dissipation	Pm			3.5	W
Data Rate			10.3125	11.2	Gbps
Control Input Voltage High		2		Vcc	V
Control Input Voltage Low		0		0.8	V
Fiber Length 9/125µm core SMF		-	-	40	KM

## Optical and Electrical Characteristics

Electrical transmitter Characteristics						
Parameter	Symbol	Min	Typical	Max	Unit	Notes
Transceiver Power-on Initialization Time				2000	ms	1
Single-ended Input Voltage Tolerance (Note 2)		-0.3		4.0	V	Referred to TP1

						signal common
AC Common Mode Input Voltage Tolerance			15		mV	RMS
Differential Input Voltage Swing Threshold		50			mVpp	LOSA Threshold
Differential Input Voltage Swing	V <sub>in,pp</sub>	190		700	mVpp	
Differential Input Impedance	Z <sub>in</sub>	90	100	110	Ohm	
Supply Current	I <sub>cc</sub>			1.1	A	
Maximum Power Consumption				3.5	W	
Maximum Power Consumption – LP Mode				1.5	W	
J2 Jitter Tolerance	Jt2	0.17			UI	
J9 Jitter Tolerance	Jt9	0.29			UI	
Data Dependent Pulse Width Shrinkage (DDPWS) Tolerance		0.07			UI	
Eye Mask Coordinates {X1, X2 Y1, Y2}			0.11, 0.31 95, 350		UI mV	Hit Ratio =5x10 <sup>-5</sup>
Signaling Speed Operating Range			±100		ppm	
Transmitter Differential Input Impedance			100		ohms	
Transmitter Differential Input Voltage		0.2		1.6	V	

#### Electrical receiver Characteristics

Parameter	Symbol	Min	Typical	Max	Unit	Notes
Single-ended Output Voltage		-0.3		4.0	V	Referred to signal common
AC Common Mode Output Voltage			7.5		V	RMS
Differential Output impedance			100		mVpp	
Differential output voltage		300		850	mV	
Termination Mismatch at 1MHz				5	%	
Differential Output Return Loss		See IEEE 802.3ba 86A.4.2.1			dB	10MHz - 11.1GHz
Common Mode Output Return Loss		See IEEE 802.3ba 86A.4.2.2			dB	10MHz - 11.1GHz
J2 Jitter Output	Jo2			0.42	UI	
J9 Jitter Output	Jo9			0.65	UI	
Eye Mask Coordinates {X1, X2 Y1, Y2}			0.29, 0.5 150, 425		UI mV	Hit Ratio =5x10 <sup>-5</sup>

#### Optical transmitter Characteristics

Parameter	Symbol	Min	Typical	Max	Unit	Notes
Data Rate Per Lane			10.3125	11.2	Gbps	
Relative Intensity Noise (RIN)				-128	dB/Hz	
Average Launch Power per lane				-30	dBm	

@ TX off state							
Transmitter Reflectance				-12	dB		
Optical return loss tolerance				12	dB		
Transmitter Eye Mask definition: X1,X2, X3, Y1, Y2, Y3		Compliant with 802.3ba standard {0.25, 0.4, 0.45, 0.25, 0.28, 0.4}					
Transmitter and dispersion penalty (TDP), each lane		-5.5			dB		
Average Launch Power per Lane	TxPx	-2.7		4.5	dBm	1	
Launch Power in OMA minus TDP, each lane		-0.3		5	dBm	2	
Difference in launch power between any two lanes (OMA)				4.7	dB		
Launch power (OMA) minus TDP per lane		-0.5			dBm		
Total Output Power	Pout			10.5	dBm		
Wavelength Assignment	$\lambda_0$	1264.5	1271	1277.5	nm		
	$\lambda_1$	1284.5	1291	1297.5			
	$\lambda_2$	1304.5	1311	1317.5			
	$\lambda_3$	1324.5	1331	1337.5			
Spectral Width(-20dB)	$\Delta\lambda$			1	nm		
Side Mode Suppression Ratio	SMSR	30			dB		
Extinction Ratio	ER	3.5			dB		
Transmitter Eye Mask Definition {X1, X2, X3, Y1, Y2, Y3}		{0.25, 0.4, 0.45, 0.25, 0.28, 0.4}					
<b>Optical receiver Characteristics</b>							
<b>Parameter</b>		<b>Symbol</b>	<b>Min</b>	<b>Typical</b>	<b>Max</b>	<b>Unit</b>	<b>Notes</b>
Receive Power (OMA) per Lane		RxOMA			-4	dBm	
Average Receive Power per Lane		RXPx	-19		-4.5		
Receiver Sensitivity (OMA) per Lane		Rxsens			-19	dBm	
Receiver Reflectance					-26	dB	
Difference in Receive Power between any two lanes (OMA)		P			7.5	dB	
Receiver Damage Threshold			3.3			dBm	3
LOS	Optical De-assert	Pd			-19	dBm	
	Optical Assert	Pa	-35				
LOS hysteresis				0.5		dB	
Receiver Electrical 3 dB upper Cutoff Frequency, each Lane		Fc			12.3	GHz	

## Pin Definitions

### Pin Diagram

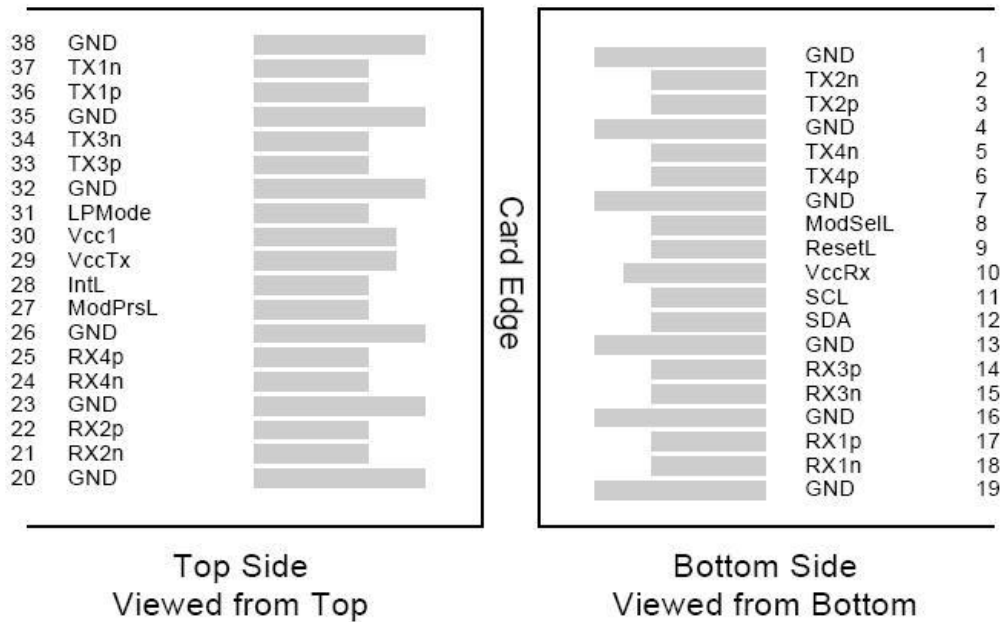

### QSFP MSA-compliant 38-pin connector

Pin	Symbol	Name/Description	Notes
1	GND	Transmitter Ground (Common with Receiver Ground)	1
2	TX2N	Transmitter Inverted Data Input	
3	TX2P	Transmitter Non-Inverted Data Input	
4	GND	Ground	1
5	TX4N	Transmitter Inverted Data Input	
6	TX4P	Transmitter Non-Inverted Data Input	
7	GND	Ground	1
8	ModSelL	Module Select	
9	ResetL	Module Reset	
10	Vcc Rx	+3.3 V Power supply receiver	2
11	SCL	2-wire serial interface clock	
12	SDA	2-wire serial interface data	
13	GND	Ground	
14	RX3P	Transmitter Inverted Data Input	
15	RX3N	Transmitter Non-Inverted Data Input	
16	GND	Ground	1
17	RX1P	Transmitter Inverted Data Input	
18	RX1N	Transmitter Non-Inverted Data Input	
19	GND	Ground	1

20	GND	Ground	1
21	RX2N	Transmitter Inverted Data Input	
22	RX2P	Transmitter Non-Inverted Data Input	
23	GND	Ground	1
24	RX4N	Transmitter Inverted Data Input	1
25	RX4P	Transmitter Non-Inverted Data Input	
26	GND	Ground	1
27	ModPrsL	Module Present	
28	IntL	Interrupt	
29	Vcc Tx	+3.3 V Power supply transmitter	2
30	Vcc1	+3.3 V Power Supply	2
31	LPMoDe	Low Power Mode	
32	GND	Ground	1
33	TX3P	Transmitter Inverted Data Input	
34	TX3N	Transmitter Non-Inverted Data Input	
35	GND	Ground	1
36	TX1P	Transmitter Inverted Data Input	
37	TX1N	Transmitter Non-Inverted Data Input	
38	GND	Ground	1

### QSFP Module PIN Definition

**Notes:**

1. GND is the symbol for signal and supply (power) common for QSFP+ modules. All are common within the QSFP+ module and all module voltages are referenced to this potential unless otherwise noted. Connect these directly to the host board signal common ground plane.
2. VccRx, Vcc1 and VccTx are the receiving and transmission power suppliers and shall be applied concurrently. Recommended host board power supply filtering is shown in Figure 3 below. Vcc Rx, Vcc1 and Vcc Tx may be internally connected within the QSFP+ transceiver module in any combination. The connector pins are each rated for a maximum current of 500mA.

## Mechanical Dimensions

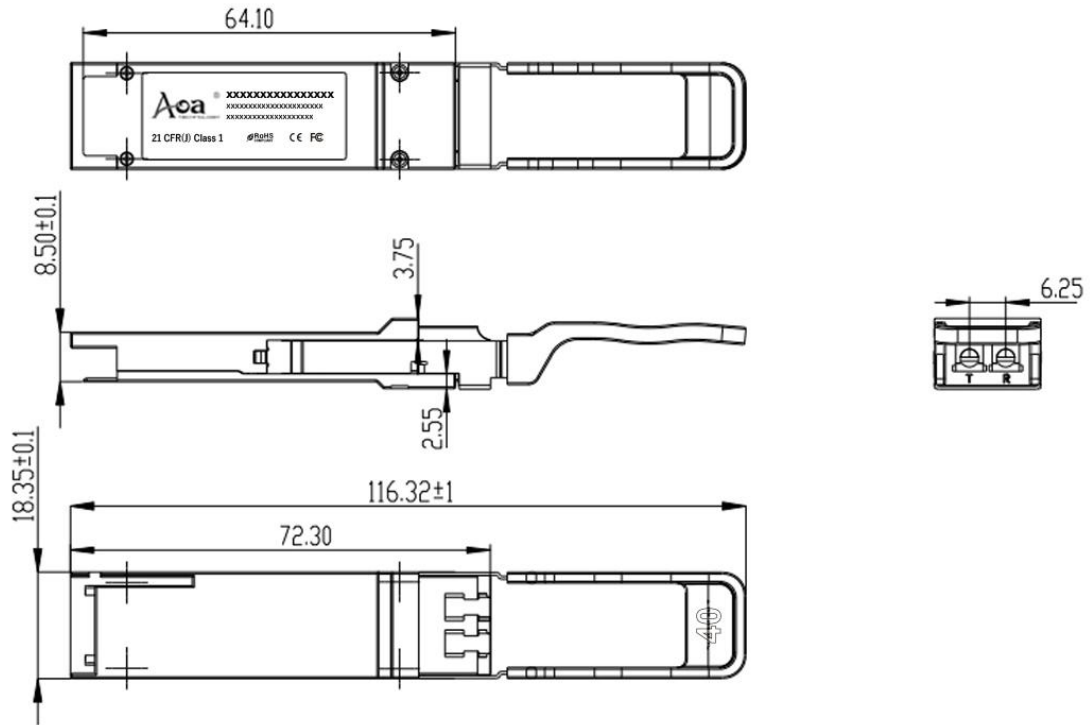

## Ordering information

Part. No	Specifications								
	Pack	Rate (Gbps)	Tx (nm)	Po (dBm)	RX	Sen (dBm)	Temp (°C)	Reach (km)	DDM
QSFP-40G-ER4	QSFP+	41.25G	DFB CWDM	-2.7~4.5	AP D	<-19.0	0~70	40	Y



For further information, please visit our website <https://www.aoatech.com>

All rights are reserved by AOA Technology Co.,Ltd. AOA reserves the right to change, modify, transfer, or otherwise revise this publication without notice, and the most current version of the publication shall be applicable.