

# QSFP28-100G-CW4

## Optical SFP Module

100Gbps QSFP28 Transceiver, CWDM4, 2KM



### Features

- Transmission data rate up to 26Gbps per channel
- 4 channels full-duplex transceiver modules
- 4 x 26Gb/s DFB-based CWDM uncooled transmitter
- 4 channels PIN ROSA
- Internal CDR circuits on both receiver and transmitter channels
- Duplex LC receptacle
- Maximum link length of 2km for SMF
- Hot Pluggable QSFP28 form factor
- Real Time Digital Diagnostic Monitoring
- Maximum power consumption 3.5W
- Single +3.3V power supply
- Compatible with RoHS
- Commercial operating case temperature: 0 to +70° C

### Application

- Data Center Interconnect
- 100G CWDM4 applications
- Infiniband EDR interconnects
- Enterprise networking

## Standard

- Compliant with IEEE 802.3bm
- Compliant with QSFP28 MSA
- Compliant with SFF-8436

## Absolute Maximum Ratings

Parameter	Symbol	Min	Max	Unit
Power Supply Voltage	Vcc	-0.3	4	V
Signal Input Voltage		Vcc-0.3	Vcc +0.3	V
Damage Threshold, each Lane	TH		5.5	dBm
Storage Temperature	Ts	-40	+85	°C
Operating Humidity	-	5	95	%

## Recommended Operating Conditions

Parameter	Symbol	Min	Typical	Max	Unit
Operating Case Temperature	Tc	0		70	°C
Power Supply Voltage	Vcc	3.135	3.3	3.465	V
Power Supply Current	Icc			1060	mA
Data Rate,each Lane			25.78125		Gbps
Link Distance with SMF	D		2		km

## Optical and Electrical Characteristics

Optical transmitter Characteristics						
Parameter	Symbol	Min	Typical	Max	Unit	Notes
Launched Power (avg.)	Pavg	-6.5		2.5	dBm	
Total Output. Power	Pout			8.5	dBm	
OMA, each Lane	POMA	-4		2.5	dBm	
TDP, each Lane	TDP			3	dB	

Wavelength Assignment	$\lambda_0$	1264.5	1271	1277.5	nm	
	$\lambda_1$	1284.5	1291	1297.5		
	$\lambda_2$	1304.5	1311	1317.5		
	$\lambda_3$	1324.5	1331	1337.5		
Spectral Width(-20dB)	$\Delta\lambda$			1	nm	
Side Mode Suppression Ratio	SMSR	30			dB	
Extinction Ratio	ER	3			dB	
Transmitter OFF Output Power	POff			-30	dBm	
Differential Line Input Impedance	RIN			-130	Ohm	
Output Eye Mask definition {X1, X2, X3, Y1, Y2, Y3}	{0.31, 0.4, 0.45, 0.34, 0.38, 0.4}					
Output Eye Diagram	Compliant with IEEE802.3ae eye mask					
Optical receiver Characteristics						
Parameter	Symbol	Min	Typical	Max	Unit	Notes
Receiver Sensitivity	S			-10.0	dBm	1
Stressed Receiver Sensitivity (OMA), each Lane				-7.3	dBm	
Average Receive Power, each lane		-11.5		2.5	dBm	
Receive Power (OMA), each lane				2.5	dBm	
Receiver Electrical 3 dB upper Cutoff Frequency, each Fc Lane	FC			31	GHz	
Optical Power Input Overload	$P_{in-max}$	4.5			dBm	
LOS	Optical De-assert	$P_d$		-14	dBm	
	Optical Assert	$P_a$		-16		
LOS Hysteresis	LOSH	0.5		2	dB	
Vertical Eye Closure Penalty	VECP	1.9			dB	
Stressed Eye J2 Jitter	J2	0.33			UI	
Stressed Eye J4 Jitter	J4	0.48			UI	

**Notes:**

1. Measured with a PRBS 2<sup>31</sup>-1 test pattern, @25.78Gb/s, BER<10<sup>-12</sup>.

## Pin Definitions

### Pin Diagram

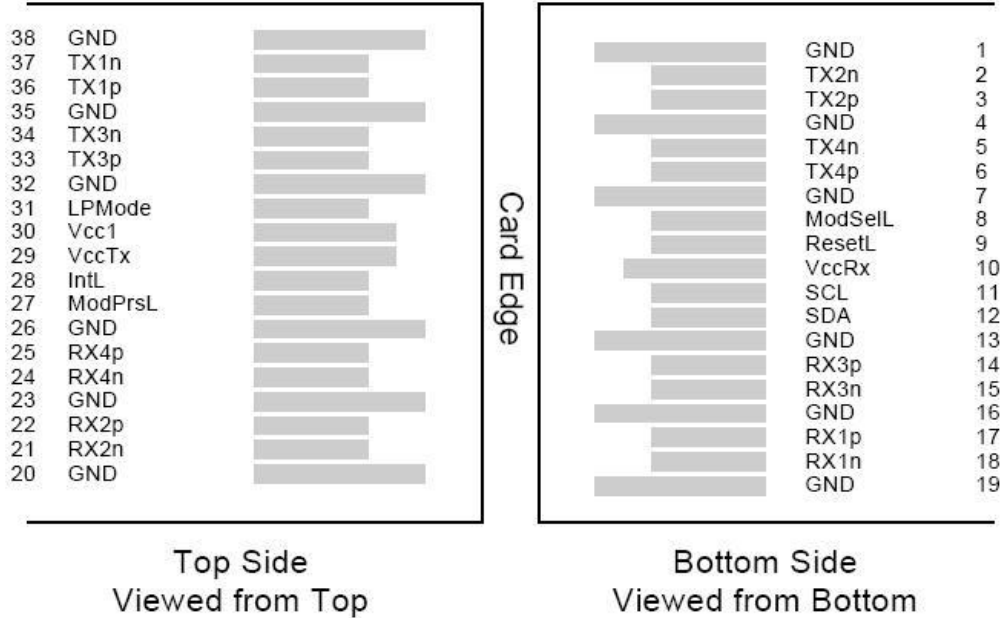

### QSFP MSA-compliant 38-pin connector

Pin	Symbol	Name/Description	Notes
1	GND	Transmitter Ground (Common with Receiver Ground)	1
2	TX2N	Transmitter Inverted Data Input	
3	TX2P	Transmitter Non-Inverted Data Input	
4	GND	Ground	1
5	TX4N	Transmitter Inverted Data Input	
6	TX4P	Transmitter Non-Inverted Data Input	
7	GND	Ground	1
8	ModSelL	Module Select	
9	ResetL	Module Reset	
10	Vcc Rx	+3.3 V Power supply receiver	2
11	SCL	2-wire serial interface clock	
12	SDA	2-wire serial interface data	
13	GND	Ground	1
14	RX3P	Transmitter Inverted Data Input	
15	RX3N	Transmitter Non-Inverted Data Input	
16	GND	Ground	1
17	RX1P	Transmitter Inverted Data Input	
18	RX1N	Transmitter Non-Inverted Data Input	

19	GND	Ground	1
20	GND	Ground	1
21	RX2N	Transmitter Inverted Data Input	
22	RX2P	Transmitter Non-Inverted Data Input	
23	GND	Ground	1
24	RX4N	Transmitter Inverted Data Input	1
25	RX4P	Transmitter Non-Inverted Data Input	
26	GND	Ground	1
27	ModPrsL	Module Present	
28	IntL	Interrupt	
29	Vcc Tx	+3.3 V Power supply transmitter	2
30	Vcc1	+3.3 V Power Supply	2
31	LPMoDe	Low Power Mode	
32	GND	Ground	1
33	TX3P	Transmitter Inverted Data Input	
34	TX3N	Transmitter Non-Inverted Data Input	
35	GND	Ground	1
36	TX1P	Transmitter Inverted Data Input	
37	TX1N	Transmitter Non-Inverted Data Input	
38	GND	Ground	1

### QSFP Module PIN Definition

**Notes:**

1. GND is the symbol for signal and supply (power) common for QSFP+ modules. All are common within the QSFP+ module and all module voltages are referenced to this potential unless otherwise noted. Connect these directly to the host board signal common ground plane.
2. VccRx, Vcc1 and VccTx are the receiving and transmission power suppliers and shall be applied concurrently. Recommended host board power supply filtering is shown in Figure 3 below. Vcc Rx, Vcc1 and Vcc Tx may be internally connected within the QSFP+ transceiver module in any combination. The connector pins are each rated for a maximum current of 500mA.

## Mechanical Dimensions

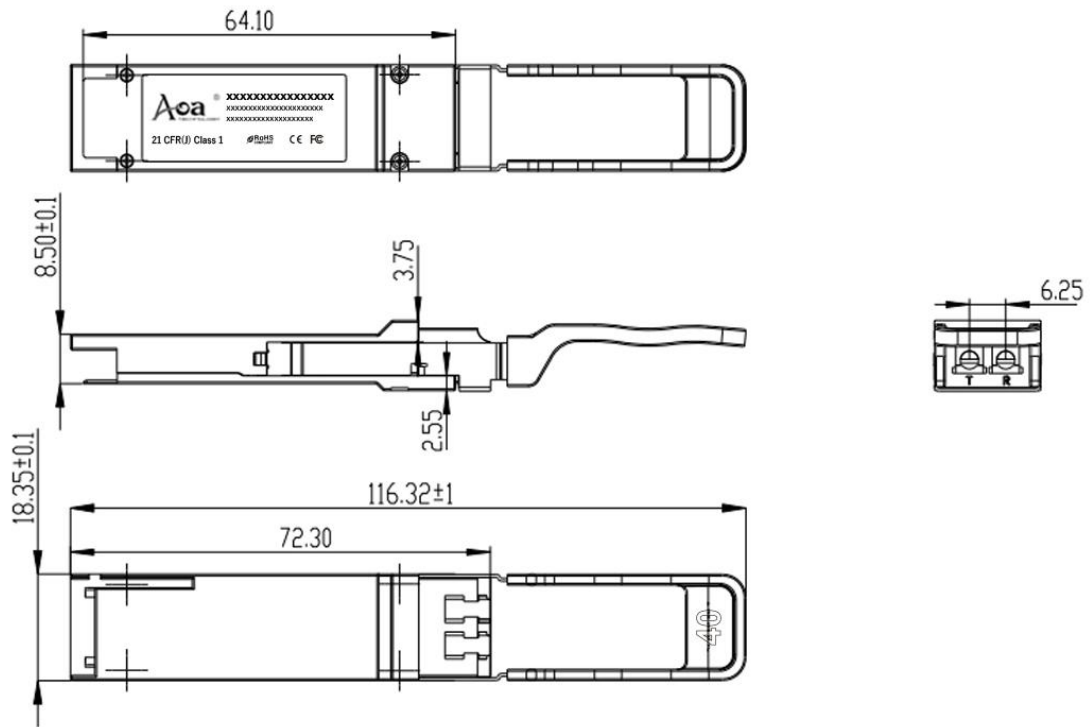

## Ordering information

Part. No	Specifications								
	Pack	Rate (Gbps)	Tx (nm)	Po (dBm)	RX	Sen (dBm)	Temp (°C)	Reach (km)	DDM
QSFP28-100G-CWDM	QSFP28	100G	DFB CWDM	-6.2~2.5	PIN	<-10.0	0~70	2	Y



For further information, please visit our website <https://www.aoatech.com>

All rights are reserved by AOA Technology Co.,Ltd. AOA reserves the right to change, modify, transfer, or otherwise revise this publication without notice, and the most current version of the publication shall be applicable.